

User Manual

ML10-ID

Version: 1.0

Date: Oct., 2015



Remarks

1. New lock is configured to grant any fingerprint or ID card access.
2. The lock is equipped with mechanical keys for manual unlocking. Remove mechanical keys from the package and keep them in a safe place.
3. To power up the lock, four alkaline AA batteries (not included) are required. Non-alkaline and rechargeable batteries are NOT recommended.
4. Press the fingerprint sensor or the sensor holder to power up the lock. To avoid unlocking the door when pressing the fingerprint sensor, pressing the sensor holder to power up the lock is recommended.
5. The operation of lock setting has a stand-by time limit of 10 seconds; if there is no any activity, the lock will shut off after 10 seconds.
6. Keep your fingers clean when using this lock.
7. To open door with ID card, you must press the sensor holder to power up the lock first.
8. Administrator and other users can choose either fingerprint or ID card for enrollment and verification.

9. Identity verification of administrator is required before enrolling other users. No matter which verification method administrator uses, other users can choose independently whether to enroll by fingerprint or ID card.

Appearance

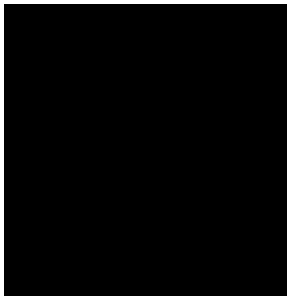

- 1 LED
- 2 Fingerprint Sensor
- 3 Sensor Holder
- 4 ID Card Swiping Area
- 5 Handle
- 6 Mechanical Key Hole
- 7 Battery Box Cover
- 8 Battery Area
- 9 Button ③ / Temporary User
- 10 Button ① / Admin user
- 11 Back LED
- 12 Button ⊖ / Delete user
- 13 Button ⊕ / Add user
- 14 Reset Button
- 15 Button ② / Normal User





Profile

User Introduction

User Type	Capacity	Privilege
Administrator	20 (Fingerprint:10, ID Card: 10)	Add/delete fingerprint or ID card; Enable Normally Open (NO) mode; Unlock the door
Normal User	120 (Fingerprint: 60, ID Card: 60)	Unlock the door; Enable NO mode
Temporary User	40 (Fingerprint: 20, ID Card: 20)	Unlock the door; Enable NO mode

Button Definition

Buttons	Function	Other functions
⊕	Add Users	
⊖	Delete Users	
①	Administrator User Group	Enable NO mode
②	Normal User Group	Enable NO mode
③	Temporary User Group	Enable NO mode

Lock Status Indication

Lock Status	Indication
Successful Operation	1 beep and LED blinks in green
Failed Operation	2 beeps and LED blinks in red
Low battery	7 beeps and LED blinks in red for 7 times
Unlocking	1 beep and electric engine makes a rolling sound for the first time, which indicates that the door is open.
Locking	Electric engine makes a rolling sound for the second time,

	which indicates that the door is closed.
--	--

Lock Initialization

Method 1

Operating Steps

Indication

Method 2

Operating Steps

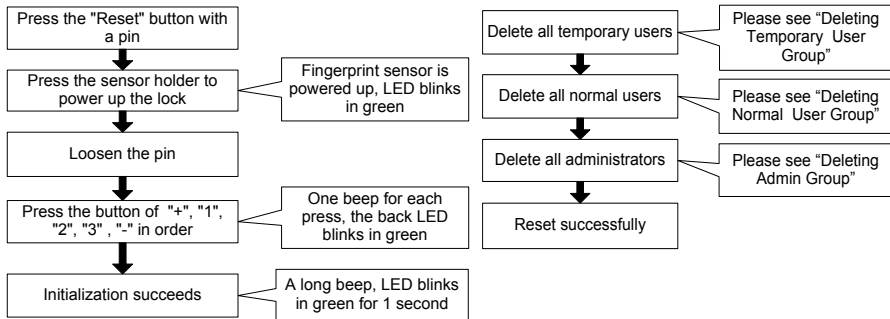

Note: The lock will be restored to factory defaults after initialization, and the door can be opened with any fingerprint or ID card.

How to use mechanical key?

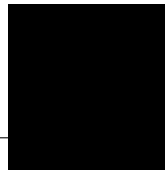
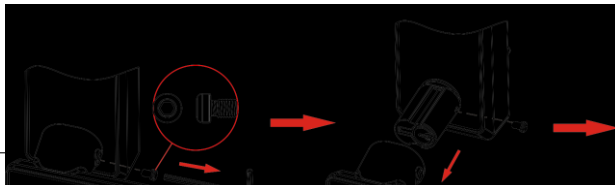

How to use 9V emergency battery?

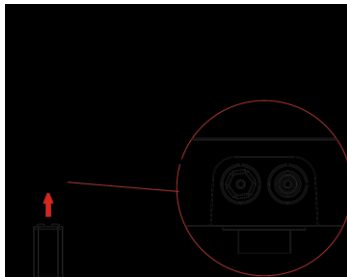

Registering First Administrator

Operating Steps

Indication

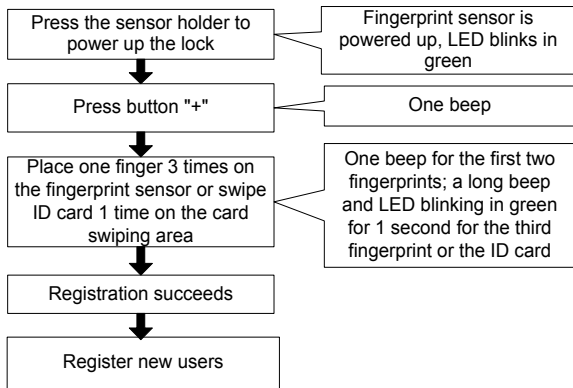

Note: 1. The first user (fingerprint or ID card) will be the first administrator automatically in default setting.

2. Admin group supports 20 users (10 for fingerprints and 10 for ID cards); you can still register 19 new administrators in the next step.

3. The operating steps of registering new users: press button 1/2/3 to select user group, and then place one new finger 3 times on the fingerprint sensor or swipe a new ID card 1 time

Registering Other Administrators

Operating Steps

Indication

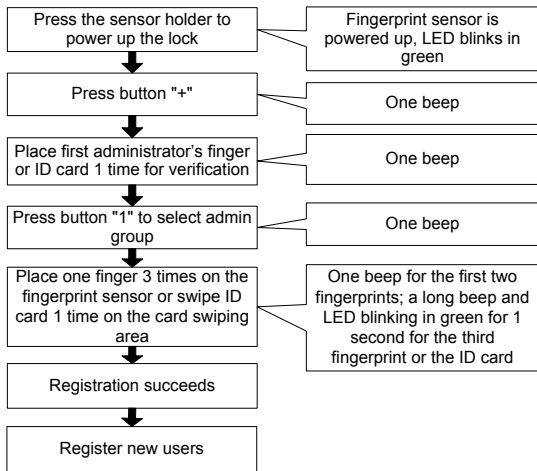

Note: Admin group supports 20 users; you can still register 19 new administrators in this step.

Registering Normal User

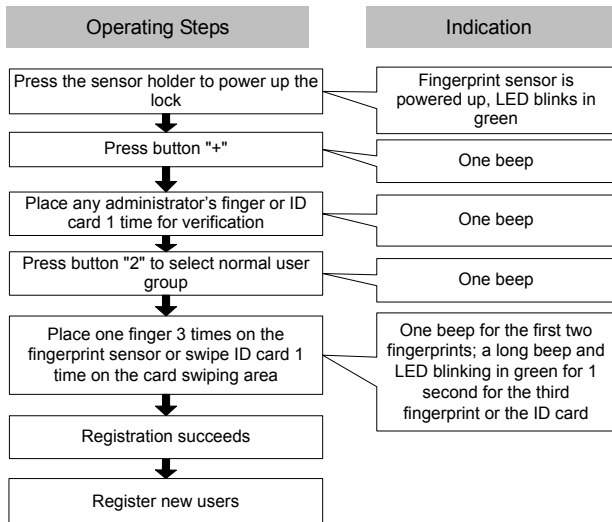

Note: Normal user group supports 120 users (60 for fingerprints and 60 for ID cards).

Registering Temporary User

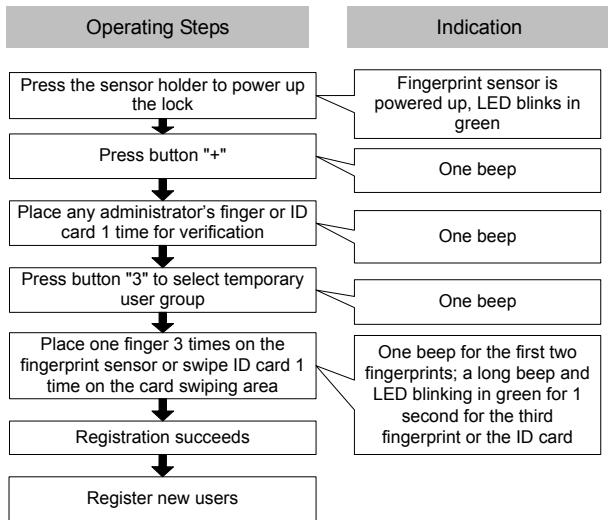

Note: Temporary user group supports 40 users (20 for fingerprints and 20 for ID cards).

Deleting Temporary User Group

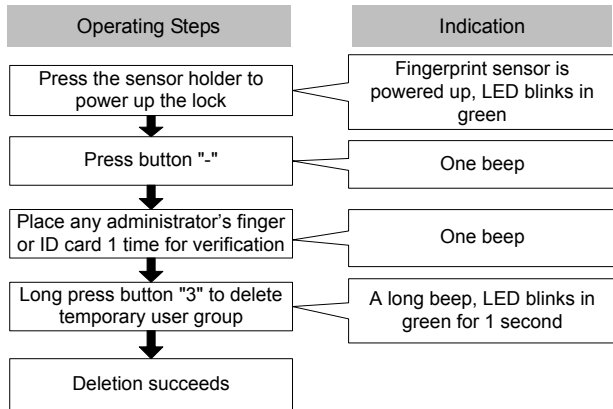

Note: Deleting operation is only valid for groups.

Deleting Normal User Group

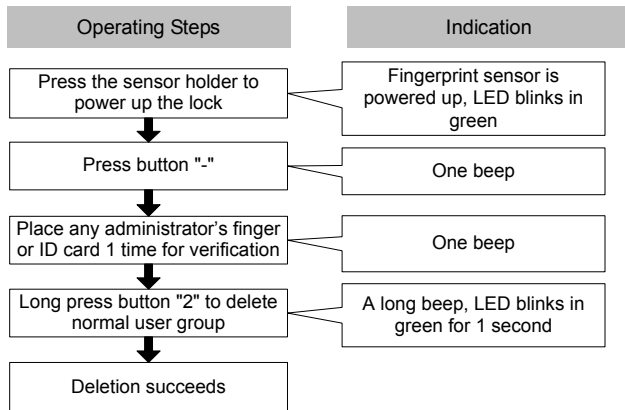

Note: Deleting operation is only valid for groups.

Deleting Admin Group

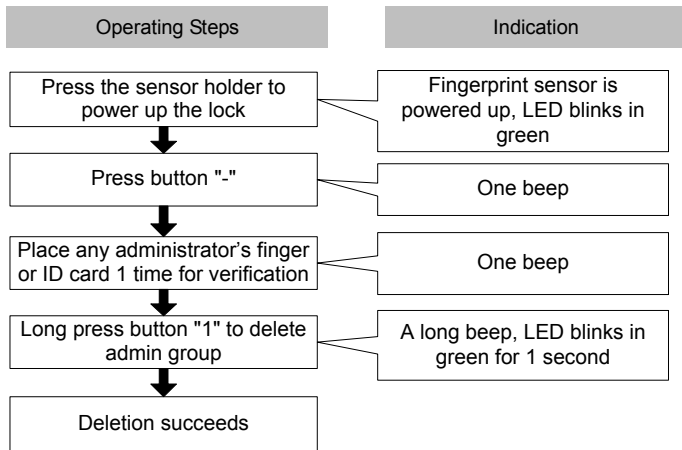

Note: Deleting operation is only valid for groups.

Enabling/Disabling Normally Open Mode

Enabling Normally Open Mode:

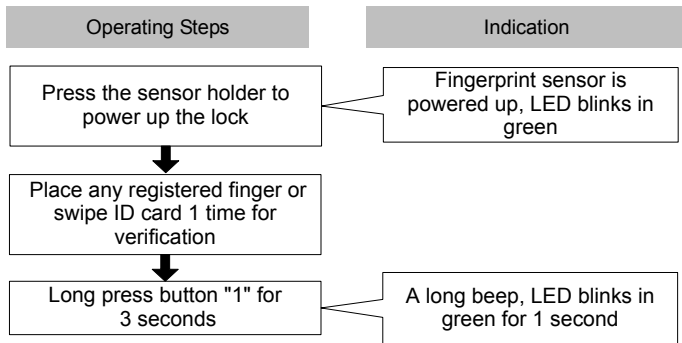

Disabling Normally Open Mode:

Press the sensor holder to power up the lock, and then place any registered finger or ID card 1 time to disable it.